

JMS-850LED3535-E28120-V1.00

850nm LED with 3535 Ceramic Package

■ Features:

- * Infrared 835~875nm Optical Wavelength
- * High efficiency and ESD threshold (HBM MIL-STD-883 Class 2)
- * Good thermal dissipation and optical uniformity
- * 3535 ceramic package with 120 degree emission angle
- * RoHs and REACH compliant
- * MSL2 qualified by J-STD-020



■ Applications:

- * Automotive
- * Data communication
- * Light Source for Infrared CCTV (Surveillance Camera)

■ Absolute Maximum Ratings

Parameter	Symbol	Rating	Unit
Storage Temperature	T _{stg}	-40 ~ +100	°C
Lead Solder Temperature*	T _{sol}	260	°C
Maximum Forward Current	I _F	600	mA
ESD threshold	HBM	2,000	V

* Solder Time < 10 seconds

■ Electrical and optical characteristics (Ta = 25°C)

Item	Parameter	Symbol	Condition	Min.	Typ.	Max.	Unit
1	DC Forward Current *	I _F	-	-	350	600	mA
2	Pulse Forward Current **	I _{PF}	-	-	-	800	mA
3	Reverse Voltage	V _R	-	-	-	-5	V
4	Reverse Current	I _R	-5V	-	-	10	uA
5	Junction Temperature ***	T _j	-	-	-	150	°C
6	Center Wavelength	λ _c	-	835	-	875	nm
7	Emission Angle	2θ _{1/2}	-	-	120	-	Deg.

* For other ambient, limited setting of current will depend on de-rating curves.

** D=0.01s , Duty Cycle 1/10

*** When drive at maximum current, Junction Temperature (T_j) must be kept below 150 °C

JMS-850LED3535-E28120-V1.00

850nm LED with 3535 Ceramic Package

■ Bin Code Selection

Drive Current (350mA)	Min (Po)	Max (Po)	Unit
P21	200	225	mW
P22	225	250	mW
P23	250	275	mW
P24	275	300	mW
P31	300	325	mW
P32	325	350	mW

Drive Current (350mA)	Min (V _F)	Max (V _F)	Unit
V1	1.4	1.6	V
V2	1.6	1.8	V
V3	1.8	2.0	V

■ Outline Dimension

Unit: mm

120°

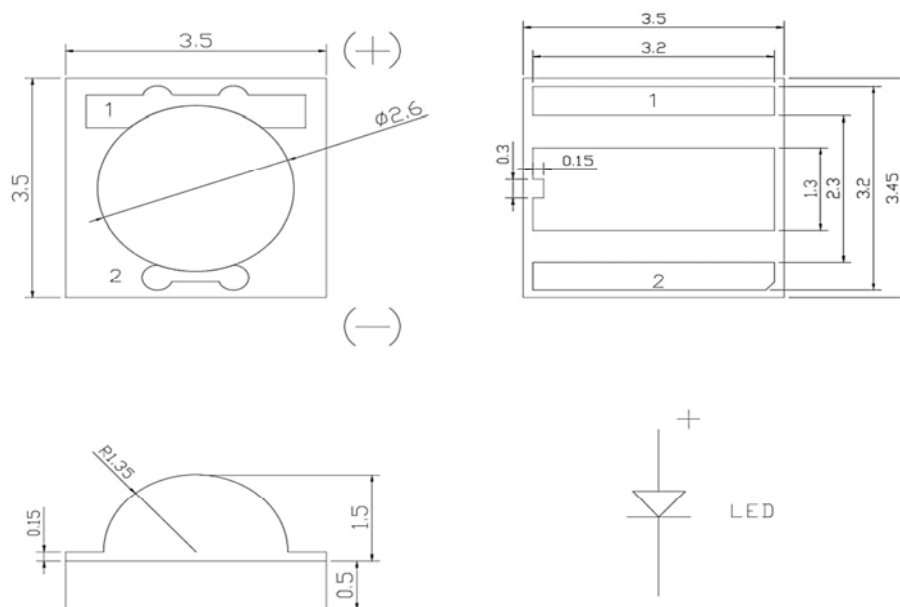

§ All dimensions are in millimeters.

§ Tolerance is ± 0.13 mm unless other specified.

JMS-850LED3535-E28120-V1.00

850nm LED with 3535 Ceramic Package

■ Relative Spectral Distribution

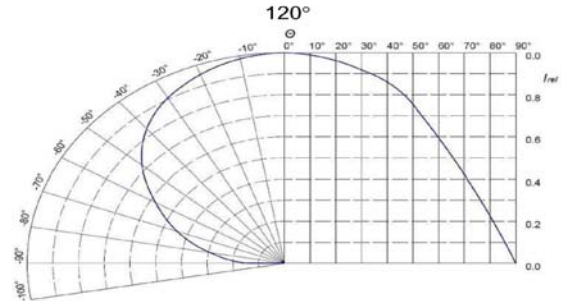
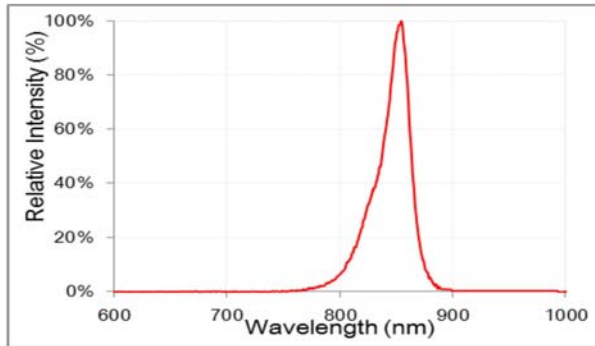

■ Relative Electronic-Optical Characteristics

Forward Current vs. Forward Voltage ($T_a=25^\circ\text{C}$)

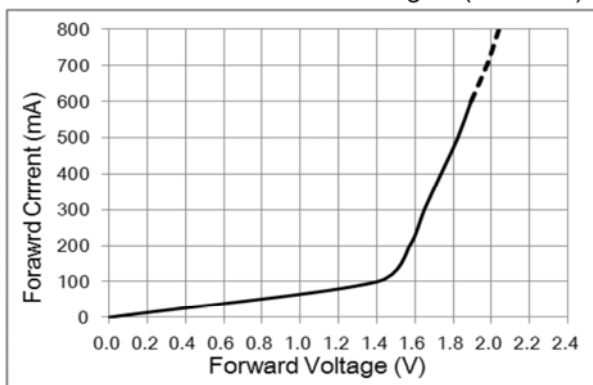

Relative Radiant Power vs. Forward Current ($T_a=25^\circ\text{C}$)

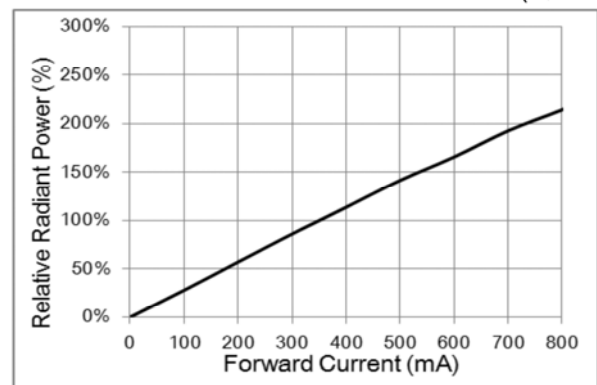

■ Thermal design for de-rating

The maximum forward current is determined by the thermal resistance between LED junction and ambient. It is crucial for the end product to be designed in a manner that minimizes the thermal resistance from solder point to ambient that would optimize the LED life and optical characteristics.

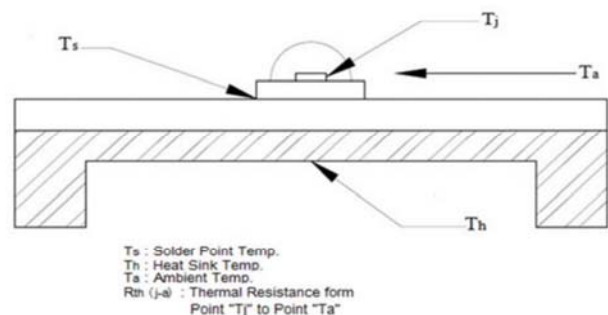
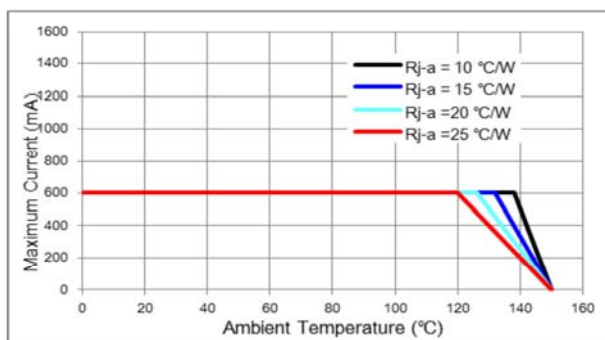

JMS-850LED3535-E28120-V1.00

850nm LED with 3535 Ceramic Package

■ Suggest Stencil Pattern

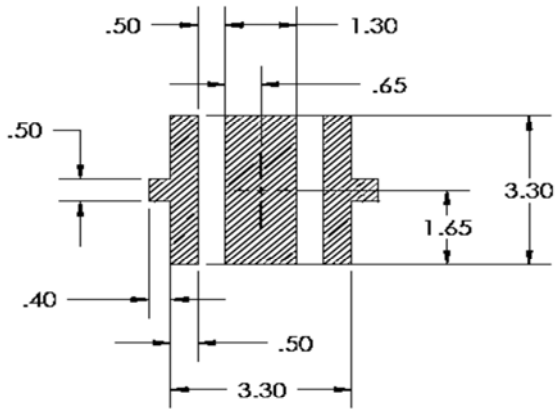

RECOMMENDED PCB SOLDER PAD

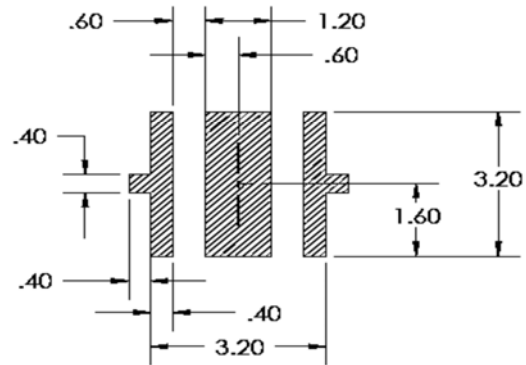

RECOMMENDED STENCIL PATTERN
(HATCHED AREA IS OPENING)

§ Suggest stencil $t = 0.12$ mm

■ IR Reflow Profile

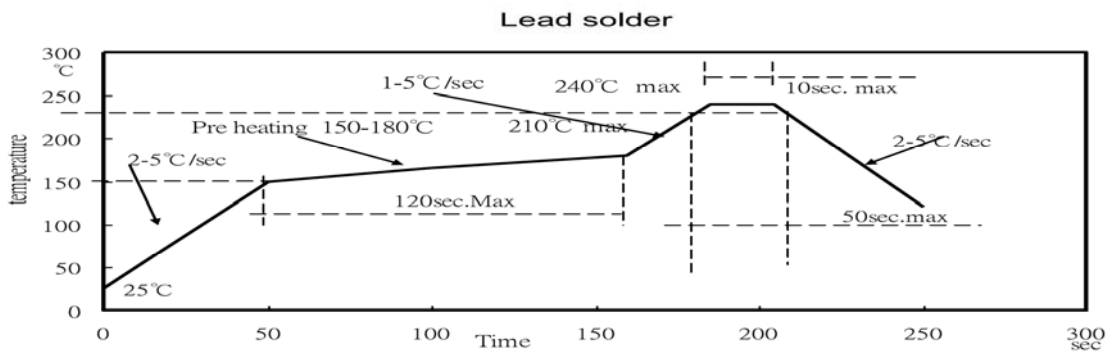
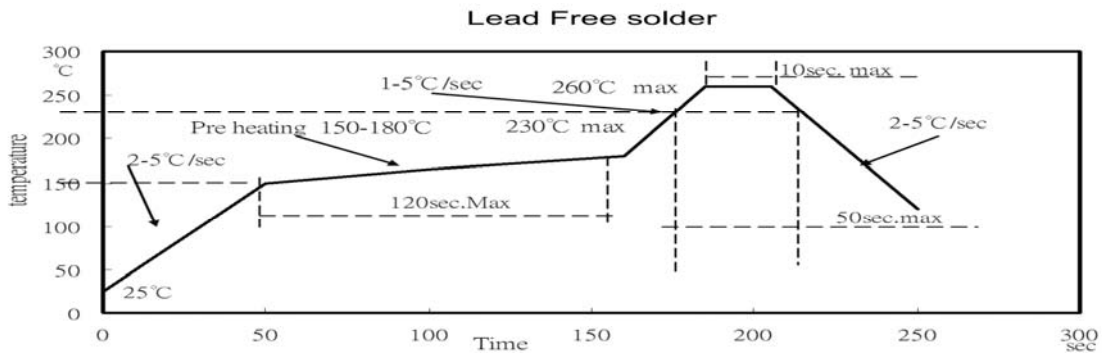

Notes:

1. The recommended reflow temperature is $240^{\circ}\text{C}(\pm 5^{\circ}\text{C})$. The maximum soldering temperature should be limited to 260°C .
2. Do not stress the silicone resin while it is exposed to high temperature.
3. The reflow process should not exceed 3 times.

JMS-850LED3535-E28120-V1.00

850nm LED with 3535 Ceramic Package

■ Precautions

1. Recommendation for using LEDs

- 1.1 The LEDs should not be exposed to dust or debris. Excessive dust and debris may cause a drastic decrease in the luminosity.
- 1.2 Avoid mechanical stress on the LED surface.
- 1.3 Do not touch the LED surface. It would affect the optical performance of the LED due to the damage of LED.
- 1.4 Pick & place tools are recommended for the remove of LEDs from the factory tape & reel packaging

2. Package handling

Please follow the guideline to pick LEDs.

- 2.1 Use tweezers to pick LEDs.
- 2.2 Do not touch the surface by using tweezers & fingers.

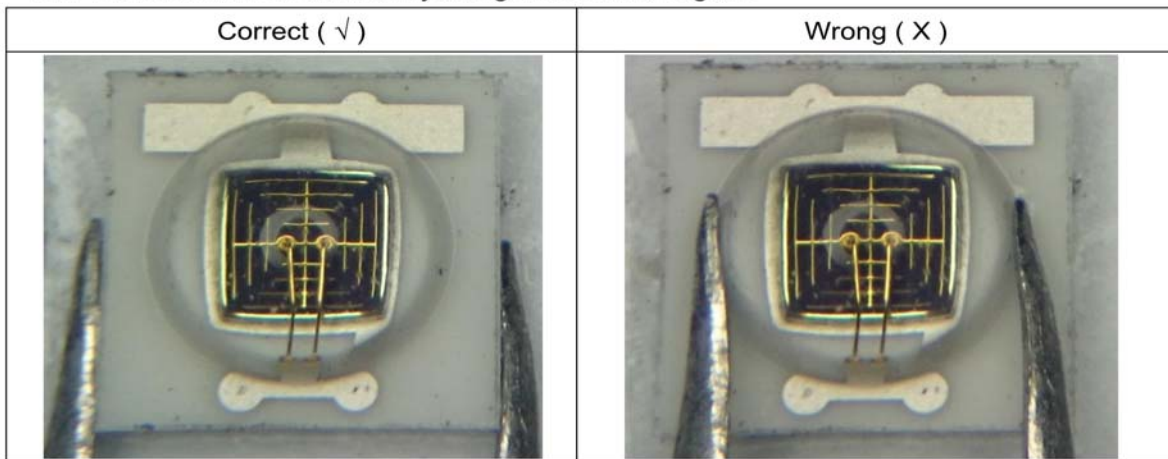

3. Surface cleaning

In the case which a small amount of dirt and dust particles remain on the surface, a suitable cleaning solution can be applied.

- 3.1 Try a gentle wiping with dust-free cloth.
- 3.2 If needed, use dust-free cloth and isopropyl alcohol to gently clean the dirt from the lens surface.
- 3.3 Do not use other solvents as they may directly react with the LED assembly.
- 3.4 Do not use ultrasonic cleaning which will damage the LEDs.

JMS-850LED3535-E28120-V1.00

850nm LED with 3535 Ceramic Package

4. Carrier tape handling

The following items are recommended when handling the carrier tape of LEDs.

- 4.1 Do not twist the carrier tape.
- 4.2 The inward bending diameter should not be smaller than 6cm for each carrier tape.
- 4.3 Do not bend the tape outward.



5. Storage

5.1 The moisture-proof bag is sealed :

The LEDs should be stored at 30°C or less and 90%RH or less. And the LEDs are limited to use within one year, while the LEDs is packed in moisture-proof package with the desiccants inside.

5.2 The moisture-proof bag is opened :

The LEDs should be stored at 30°C or less and 60%RH or less. Moreover, the LEDs are limited to solder process within 168hrs. If the humidity indicator card shows the pink color in 10% even higher or exceed the storage limiting time since opened, that we recommended to baking LEDs at 60°C at least 24hrs. To seal the remainder LEDs return to the moisture-proof bag, it's recommended to be with workable desiccants.

