

ALS-5FLAMPB-V1.00

Ambient Light Sensor in 5F Lamp Package (Black)

■ General Description

ALS-5FLAMPB photo IC, consisting of a photodiode and a current amplification IC, is a cost effective solution to the power saving of display backlighting of mobile appliances, such as the mobile phones and PDAs. Due to the high rejection ratio of infrared radiation, the spectral response of the ambient light sensor is close to that of human eyes.

■ Features

- Close to the human eye's response
- Good output linearity across wide illumination range
- Low sensitivity variation across various light sources
- Guaranteed temperature performance, -30°C to 85°C
- Wide supply voltage range, 1.8V to 5.5V
- Package Size : 5mm Lamp
- Excellent IR cut performance

■ Applications

- Detection of ambient light to control display backlighting
 - Mobile devices - mobile phones, PDAs
 - Computing devices - TFT LCD monitor for notebook computer
 - Consumer devices - TFT LCD TV, plasma TV, video camera, digital still camera
- Automatic residential and commercial lighting management
- Automatic contrast enhancement for electronic signboard
- Ambient light monitoring device for daylight and artificial light

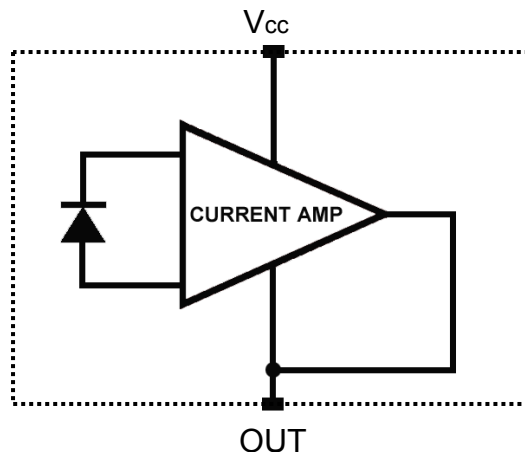

■ Pad Descriptions

<i>Pad Name</i>	<i>I/O</i>	<i>Function</i>
Vcc	Power	Power supply terminal
OUT	Output	Output terminal of the amplified photocurrent
GND	Power	Ground terminal

■ Absolute Maximum Ratings (Ta=25°C)

For implementations where case to ambient thermal resistance is < 50°C/W

<i>Parameter</i>	<i>Symbol</i>	<i>Min.</i>	<i>Max.</i>	<i>Units</i>
Storage Temperature	TS	- 40	100	°C
Operating Temperature	TA	- 30	85	°C
Supply Voltage	VCC	- 0.7	6.5	V
Output Current	IPH	-	5	mA
Output Voltage	VOUT	0	VCC	V
Electrostatic Discharge, HBM	ESD	> 8	-	KV

■ Recommended Operating Conditions (Ta=25°C)

<i>Parameter</i>	<i>Symbol</i>	<i>Min.</i>	<i>Max.</i>	<i>Units</i>
Operating Temperature	TA	- 30	85	°C
Supply Voltage	VCC	1.8	5.5	V
Output Photocurrent	IPH	0	5	mA
Output Voltage	VOUT	0	VCC - 0.7	V

■ Electrical and Optical Characteristics (Ta=25°C, Vcc=3.0V)

Parameter	Symbol	Test Conditions	Min.	Typ.	Max.	Units
Current Consumption	I _{cc}	About 1.02 times of I _{PH}				
Photocurrent	I _{PH1}	V _{CC} =3.0V, E _v =10Lx ^{[2][4]}	0.5	-	1.5	μA
Photocurrent	I _{PH2}	V _{CC} =3.0V, E _v =100Lx ^{[2][4]}	5	-	15	μA
Photocurrent	I _{PH3}	V _{CC} =3.0V, E _v =1000Lx ^{[1][4]}	50	-	150	μA
Photocurrent	I _{PH4}	V _{CC} =3.0V, E _v =1000Lx ^{[1][4]}		96		mA
Dark Current	I _{DARK}	V _{CC} =3.0V, E _v =0Lx	-	-	100	nA
Photocurrent Ratio	I _{PH4} / I _{PH3}	V _{CC} =3.0V, E _v =1000Lx	-	1.2	-	-
Peak Sensitivity Wavelength	λ _P		-	560	-	nm
Sensitivity Wavelength Range	λ		390	-	700	nm
Rise Time	T _r	V _{CC} =3.0V R _f =27KΩ	-	0.36	-	ms
Fall Time	T _f	V _{CC} =3.0V R _f =27KΩ	-	1.13	-	ms
Angle of half sensitivity	2θ 1/2	I _F =20mA	-	143	-	Deg.

Note

1. Illuminance by CIE standard illuminant-A / 2856K, incandescent lamp.
2. Fluorescent light is used as light source. White LED is substituted in mass production.
3. White LED is used as light source.
4. The actual photocurrent depends on the package and optical designs.

Typical Electrical and Optical Characteristics Curves

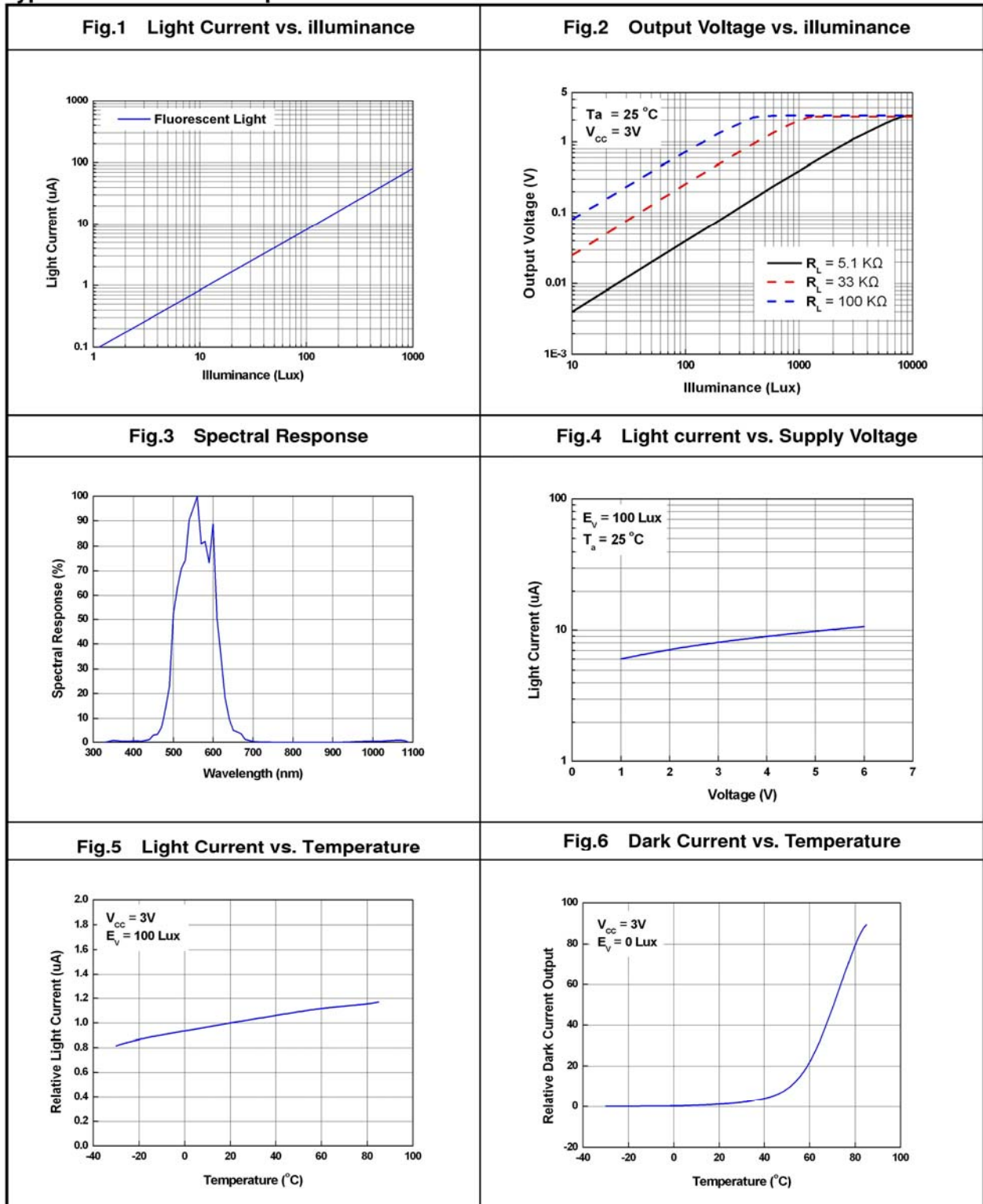

■ Outline Dimensions & Structural Drawing

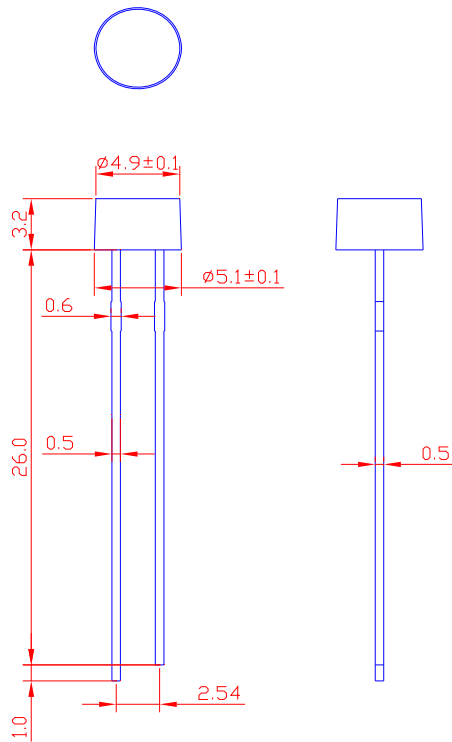

Long Pin: VDD

Short Pin: Out

ITEM	MATERIALS
Resin(Mold)	Epoxy
Lens Color	Black Transparent
Lead Frame	Ag Plating Iron Alloy

All dimensions are in mm.

All tolerances are ± 0.1 mm

■ Converting Photocurrent to Voltage

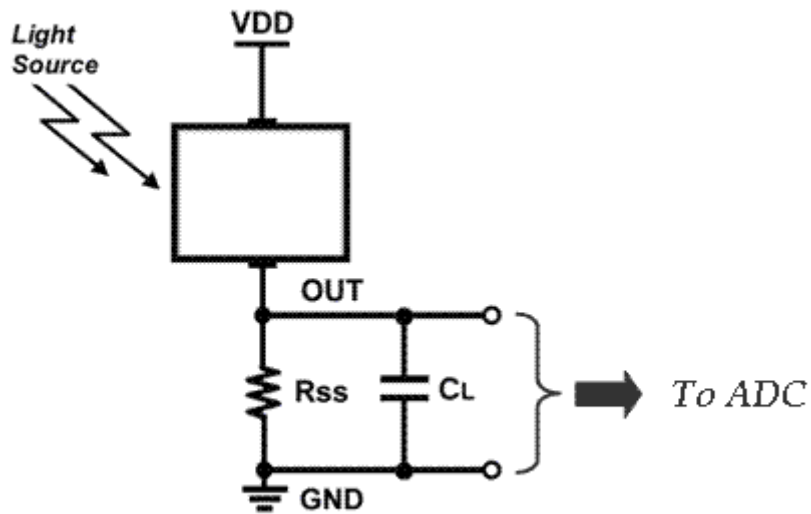

- The output voltage (V_{OUT}) is the product of photocurrent (I_{PH}) and loading resistor (R_L).
- A right loading resistor should be chosen to meet the requirement of maximum ambient light, and the output saturation voltage:
$$V_{OUT(max.)} = I_{OUT(max.)} \times R_L < V_{out(saturation)} = V_{CC} - 0.7 V$$
- To avoid 60Hz ripple from fluorescent lamps, we suggest that the time constant must be greater than 0.5 second: $R_L \times C_L > 0.5$ (empirical data)